

# INSTALLATION MANUAL



## QUADRA Drinking Water System

For Quadra Models:  
Compact, 420, 440, 460, 4100, 4180,  
Plus 5, Plus 9 and Plus 15

**Billi**<sup>TM</sup>  
LW



**Billi Pty Ltd**

42 Lucknow Crescent,  
Thomastown  
Victoria 3074

Tel: +61 9469 0400  
Fax: +61 39469 0499  
Email [info@billi.com.au](mailto:info@billi.com.au)

**Service & Support**  
[Service@billi.com.au](mailto:Service@billi.com.au)  
Tel: 1300 300 316

## Installation Requirements

### Components for Billi Quadra Compact, 420, 440, 460, 4100 & 4180 Models

Before commencing installation, ensure you have identified the following.

1. Underbench module
2. Dispenser upper with tubing
3. Dispenser base & mount
4. Barb locking bush
5. 4mm chrome screw & allen key
6. Large washer
7. Tube spring clamps x 3
8. 450mm flexible braided hose
9. Drain fittings (water-cooled only)
10. Behind door panel:
  - a. filter cartridge(s)
  - b. User Guide
  - c. Warranty registration card

### Determine Unit Location

Plan the installation. Dispenser tube lengths, position of power and water outlets, required air space around the underbench module and access for service must be considered before cutting tube lengths. Refer to Diagrams 1 and 2 and the table below for clearances around unit. Unit must be installed horizontally with display panel facing to front of cupboard. The **Quadra** is designed for internal installation only.

Model	Height	Width	Depth	Min side clearance	Cupboard min width	Cupboard min depth	Weight Kg
Compact W/cool	340mm	315mm	350	10mm	335	365	26
Compact A/cool	340mm	315mm	395	25mm	365	410	28
Quadra W/cool	340mm	315mm	465	10mm	335	475	30
Quadra A/cool	340mm	315mm	510	25mm	365	520	32

### Water Supply

The **Quadra** must only be connected to a **cold water** supply. A 15mm stop tap (not supplied) is to be installed in an easily accessible position within 450mm from the **Quadra** water supply inlet. The **Quadra** incorporates a certified pressure limiting and backflow prevention device. Do not fit an additional pressure limiting valve.

Water supply pressure: min. 200kPa, max. 1000 kPa.

Supply temp: min. 5°C, max. 30°C.

**Do not install with water that is microbiologically unsafe or with water of unknown quality without adequate disinfection before or after the system. Systems certified for cyst reduction may be used on disinfected water that may contain filterable cysts.**

### Power Requirements

A single 3 pin GPO is required. A dedicated circuit should be provided and must be fitted with an earth leakage protection device (RCD). An externally fitted RCD device is acceptable. Models **Quadra Compact 420, 440, 460** and **Plus 9** require a 10 amp rating. Models **4100** and **Plus 15** require a 15 amp rating. Model **4180** requires a 20 amp rating. All **Quadra** models are supplied with a 1-metre flex cord and plug.

### Drainage

Water-cooled **Quadra** models require a drainage point such as a dishwasher nipple. Use the nipple adaptor fitting supplied or the clamp-on drain adaptor (also supplied with system). Clamp-on drain adaptor must be installed above the water seal on the sink side of the water trap. The **Quadra** dispenser incorporates an externally vented air gap.

### Ventilation

Air-cooled **Quadra** models require cupboard ventilation, adequate air space and an unobstructed clearance of at least 25mm on each side of the underbench unit. Door ventilation is to be provided in the bottom and top of the cupboard door (Diagram 3). Suitable vent grills are available from Billi Pty Ltd (Part no: 101301). For high usage installations, an optional low voltage door fan kit is available and should be fitted if cupboard internal temperatures exceed 35°C (Billi Part no: 101302).

**IMPORTANT: Insufficient ventilation will cause inefficient refrigeration system operation, increasing power usage.**

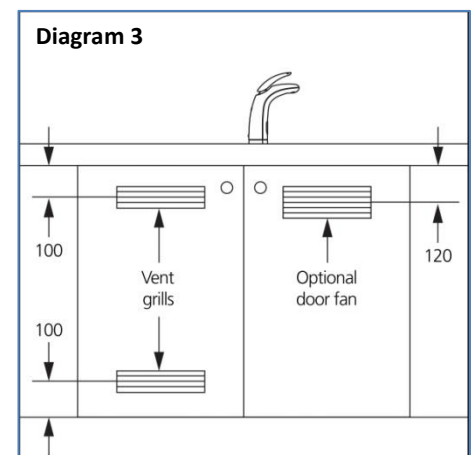
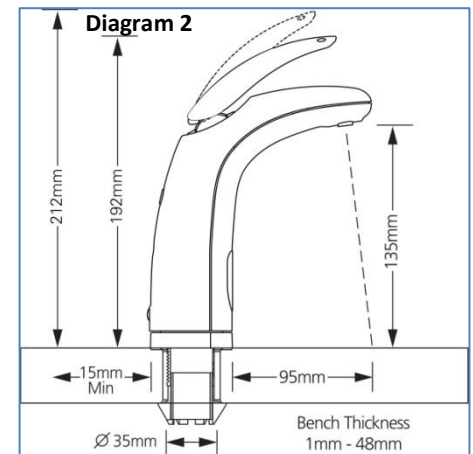
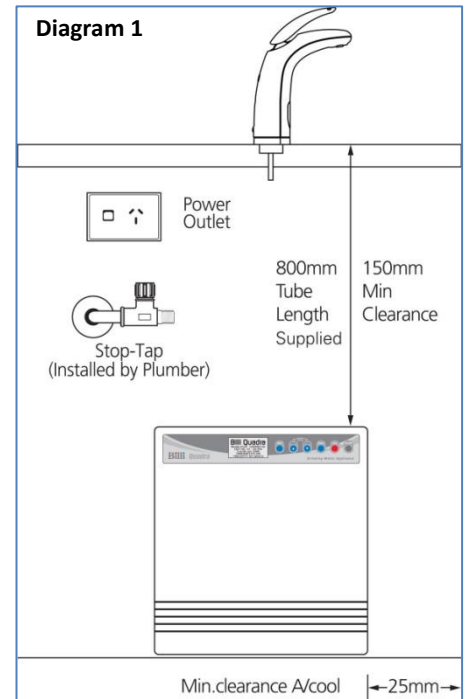

## Installing Dispenser

**IMPORTANT:** this Billi appliance is to be installed by a licensed tradesperson in accordance with AS 3500.4 or AS/NZ 3500.4.2 and in compliance with applicable state regulatory requirements. For correct operation of this appliance, it is essential to observe the manufacturer's instructions.

### Install Dispenser Assembly

Determine position of dispenser mounting hole in sinktop or benchtop. Dispenser base template may be cut out and used to assist in correct positioning. Refer to Diagram 2 for clearances allowed. Hole size required is  $\varnothing 35\text{mm}$ .

### Stainless Steel Sinktop

A suitable 35mm hole punch (Part no: 200001) is available as an accessory from Billi Pty Ltd. If possible, cut hole with die mounted below the sinktop surface so that burr is pulled downwards. Alternatively, remove burr and radius edge of hole with fine file. This allows barbed dispenser mount to slide smoothly into mounting hole. Oil hole punch regularly. Lubricate surface to be cut with detergent.

### Timber/Laminate Benchtop

Maximum benchtop thickness is 48mm. Cut 35mm hole in appropriate position. When drilling through a particle board bench top, take care to avoid a large chip breaking away as drill breaks through underside surface. We recommend drilling a small pilot hole through benchtop, partially drilling the 35mm hole from underneath and then completing drilling the hole from above. The large 30mm washer supplied may be used to secure barb where underside particle board bench top has chipped away.

### Fit Dispenser Base

1. Cut a 35mm hole in sinktop or benchtop. Remove burr if protruding upwards.
2. Press barbed mounting shaft through mount hole. Finger tighten nut.
3. Insert barb locking bush as shown in Diagram 4.
4. Ensure barb is centred in mount hole before tightening. Check position of base ring and gasket.
5. Moderately tighten locking nut using multigrips or spanner. Take care to avoid overtightening nut which may break the plastic threaded shaft.
6. Place large washer over thread as shown in Diagram 5.
7. Cut off excess threaded shaft with a hacksaw, using washer as a cutting guide.

**IMPORTANT:** Remove burrs and check internal bore is completely smooth.

### Fit Dispenser Head Assembly

1. Lay dispenser head assembly alongside mounting base assembly.
2. Feed dispenser tubing and loom through centre hole in the following order:
  - Dispenser power cord.
  - 5mm and 10mm black drain tubes (water-cooled)
  - Grey vent silicone tube. Feed tube until reducing join passes through mount assembly – see Diagram 6.
  - Red and blue silicone tubing. To assist feeding the tubing, we recommend using silicone spray lubricant. Do not attempt to force tubing through with a pointed object as silicone tube is easily punctured. Check tubing is not kinked or twisted.
3. Turn dispenser head assembly to approximately  $60^\circ$  from the straight ahead position of dispenser base. Slide head assembly onto base assembly whilst gently pulling tubing downwards from underneath to prevent tubing bunching and kinking. Mounting lugs will pass nut and slide down the 3 grooves on the swivel bearing.
4. Once fully down, turn dispenser to straight ahead position. Fit chrome plated M4 retaining screw to lower rear threaded hole and tighten using the allen key supplied. Check dispenser now swivels smoothly  $45^\circ$  in each direction.

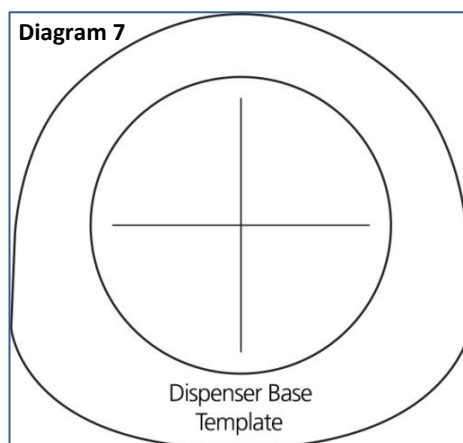
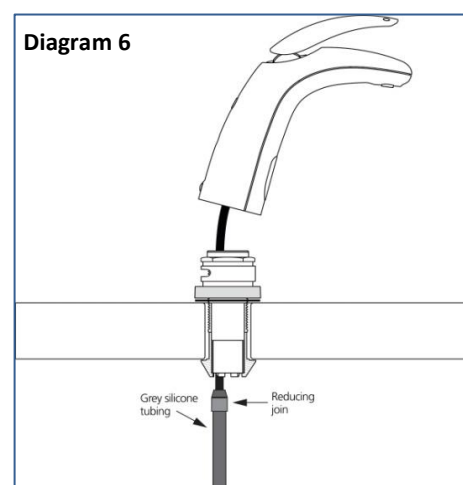
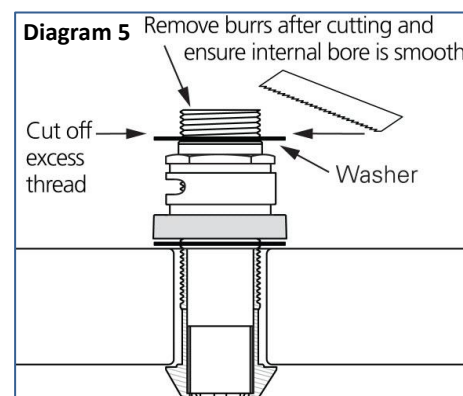
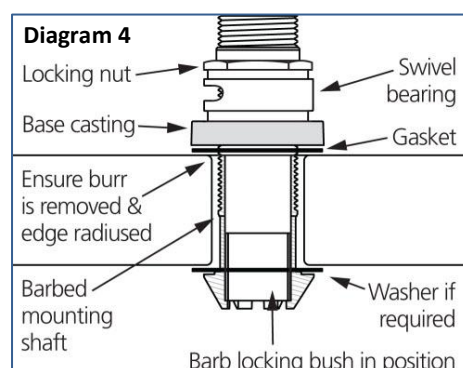

## Installing Underbench Module

### Flush Water Supply

1. Flush water supply pipework before installing the underbench unit by connecting 450mm flexible braided hose to the supply tap and running water into a bucket.

### Install Underbench Unit

2. Take care to observe minimum clearances. This is particularly important with air-cooled models. Ensure there is adequate access to service the unit.

### Connect Dispenser Tubing and Electrical Plug

3. Connect all tubing and electrical plug as shown. For **Quadra Compact** – refer to Diagram 7. For **Quadra 420 to 4180** – refer to Diagram 8. For **Quadra Plus 9** and **Quadra Plus 15**, refer to Diagram 8 and additional instructions on the following page.

Ensure correct orientation of dispenser power plug before insertion. Trim tubes to correct lengths using a sharp knife or plastic tube cutter. Avoid leaving excess tubing which will sag, trapping water. Fit spring clamps supplied to retain silicone rubber tubing to barbed fittings. 5mm black refrigeration cooling tube is fitted to a compression nut type fitting. Refer to Diagram 10. Nut to be finger tightened only.

**IMPORTANT: BOILING OUTLET (RED), VENT TUBE (GREY) AND 10MM BLACK DRAIN TUBE MUST NOT BE KINKED AND MUST BE INSTALLED WITH A CONTINUAL FALL.**

### Connect Drain Tube

4. Connect black 10mm drain tube to dishwasher nipple or alternative drainage point using fittings supplied. DRAIN TUBE MUST BE INSTALLED WITH A CONTINUAL FALL.

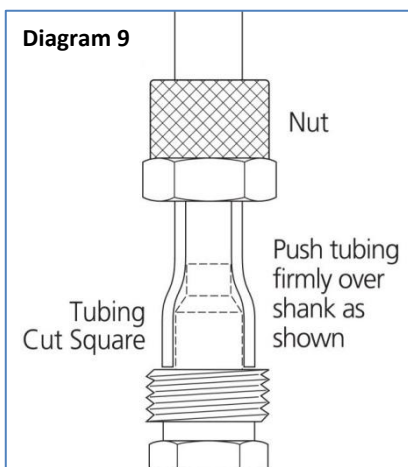
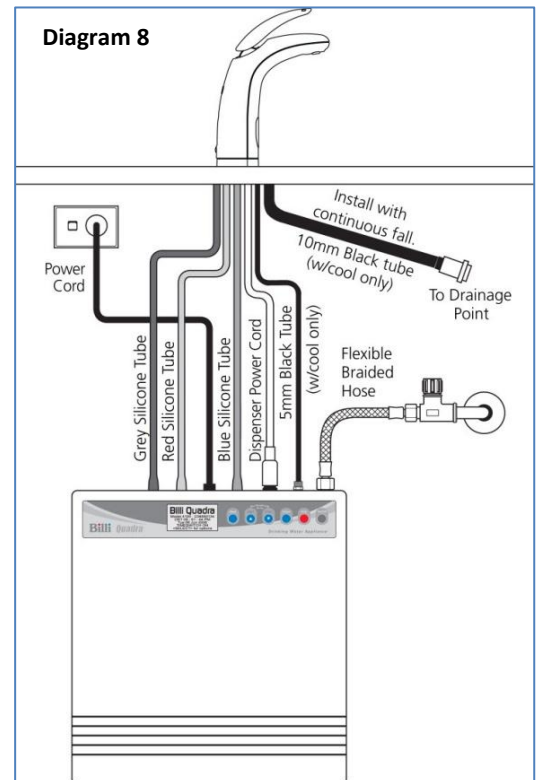
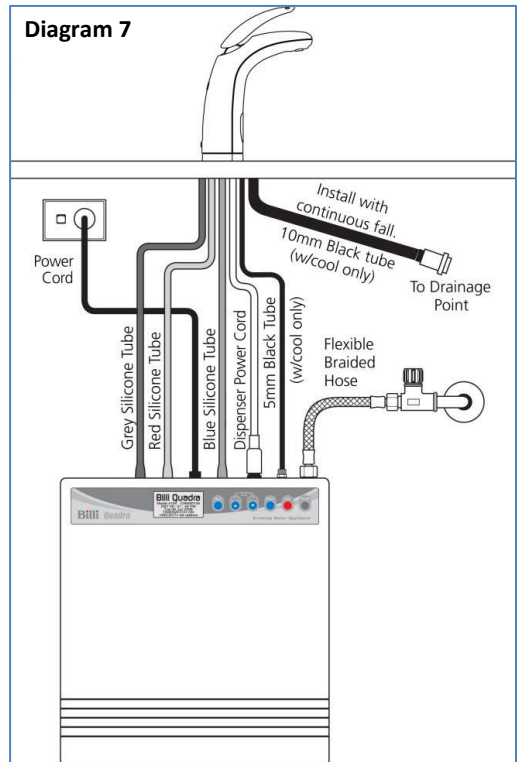

## Installing Quadra Plus 9 and Plus 15 Mixer Tap

### Additional Components for Billi Quadra Plus 9 and Plus 15 Models

Before commencing installation, identify the following components:

- |                                 |                                    |
|---------------------------------|------------------------------------|
| 1. O-ring (large)               | 8. Barb adaptor fitting (extended) |
| 2. Tap base ring                | 9. 9. Spring hose clamps x 2       |
| 3. Mount clamp plate            | 10. 15mm (1/2") joining nipple     |
| 4. Mount clamp plate gasket     | 11. 1-metre PVC tubing             |
| 5. Mount stud                   | 12. Braided flexible couplings x 3 |
| 6. Extended fixing nut          | 13. Mixer tap                      |
| 7. Barb adaptor fitting (short) |                                    |

### Mixer Tap Mounting Procedure

- Drill or punch mount hole and deburr.
  - Hole size: 35 – 38mm.
  - Sink or Benchtap thickness: 1 – 48mm.
- Feed braided flexible couplings marked 'Water In' and 'Water Out' through mount hole leaving M10 threaded connection ends protruding upwards through hole. Fit O-ring (large) and tap base ring over tubes and sit them in place.
- Fit barb adaptor fitting (extended) and mount stud to mixer tap body.
- Push PVC tubing onto barb and fit spring hose clamp. Position hose clamp lugs as shown in Diagram 10.
- Feed PVC tube down through mount hole alongside braided tubes.
- Fit M10 threaded tubes into tap body. Match tube labels with tap base markings.
- Feed tubing through the mount hole and place tap in correct position. Mount stud faces to front of mixer tap. Move lever from left to right to find lever centre position.
- Fit mount clamp gasket and plate to mounting stud. Note orientation of gasket and plate – see Diagram 11.
- Ensure tap is positioned evenly over the mount hole and that lever position is correct. Fit and tighten extended nut using a 12mm tube spanner or large flat blade screwdriver.

### Connecting Mixer Tap to Quadra Plus

Fit tubing connections as shown in Diagram 12.

- Water supply inlet tube incorporates an inline strainer. Connect to 15mm (1/2") stop tap.
- Fit short barb adaptor to port at the rear of **Quadra** unit marked 'Hot Outlet'. Trim PVC tubing to correct length using sharp knife. Excess tubing will cause sagging and possible kinking. Push tube onto barb adaptor and fit spring hose clamp. Support may be needed for PVC tube if there is a horizontal run.
- Fit braided coupling marked 'Hot Inlet' to matching port. Join to braided coupling marked 'Water Out' using 15mm (1/2") joining nipple.

### Operating the Mixer Tap

Operation of the mixer tap is as with any single lever tap.

Lift lever to start water flow. Swing to the left for hot water and to the right for cold water.

Hot water will not be available until **Quadra** boiling water tank has filled and heated.

Bubbling in the hot water flow indicates insufficient boiling water is available. Wait a few minutes for tank to fill and heat.

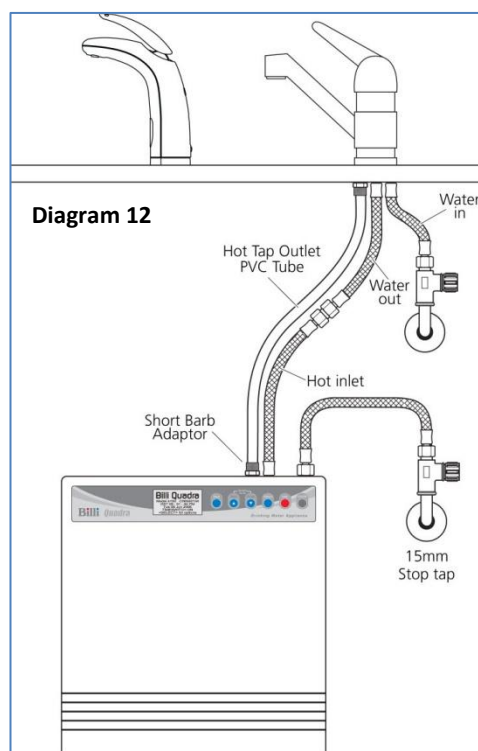
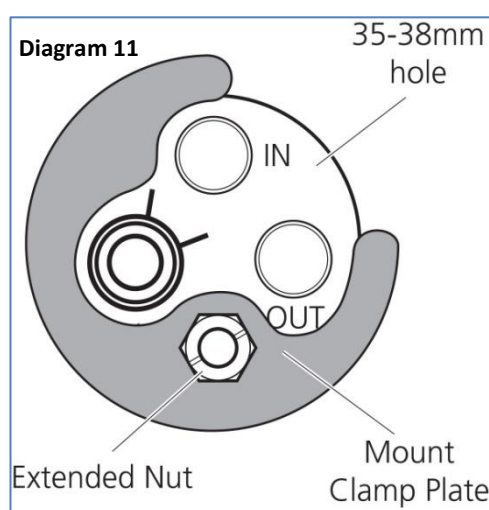
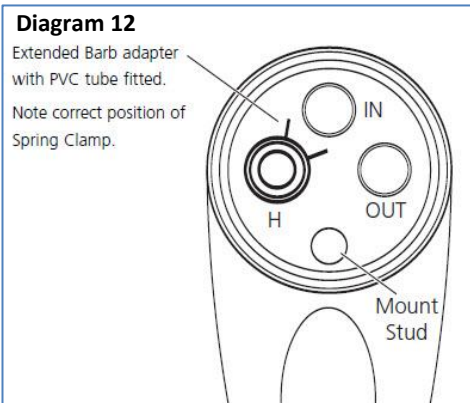

## Commissioning

### Turn On Water Supply

Turn on the water supply tap and check there are no leaks.

### Turn On Electricity

Turn on power switch. Check normal time display is showing. Status line should display 'INITIAL FILL'. Boiling and chilled water tanks are now filling. Dispenser icons flash orange slowly.

### Cold Water

During the initial fill, cold water valve automatically opens to fill the cold tank. After approximately 1 minute, cold water will begin to flow from the dispenser outlet. Water will continue to run for a further minute to flush and condition the filters.

### Hot Water (Auto Boiling Calibration)

Auto Boiling Point Calibration: The hot tank will first fill to the height of the low level sensor. The water is then heated until it reaches boiling point. The unit will continue to boil for up to 30 seconds while the temperature sensor calibrates. **WARNING:** Steam and small amount of hot water may be discharged from the taps and vent during this period. While calibration is underway the hot water indicator (red) will double blink rapidly. The hot water set point is calibrated 1.5C below the boiling point. Once calibrated, the unit will resume normal operation and the calibration data will be saved. The unit will not re-calibrate under normal circumstances.

### Setting the Programs

The **Quadra** operational settings have been factory set for a typical installation. Clock is set to Eastern Standard Time (EST). Refer to **Quadra User Guide** for setting instructions. In some installations, boiling water delivery settings may need to be changed as outlined below.

### Entering tube length setting for correct boiling water flow

The **Quadra's** boiling water flow rate slows briefly as water first enters the cup to prevent splashing. Correct timing of the moment of reduced flow is dependent on the length of the tube between the **Quadra** module and the dispenser. The standard timing is set for a tube length of 500mm but this setting can be simply altered to suit the installation.

After installation, measure the length of the red tube from the underside of the dispenser to the boiling water outlet fitting. If the measured length is less than 450mm or greater than 550mm, the correct value should be set in as follows:

1. Press **SELECT**. Display changes to menu selection mode.
2. Press **▲** 4 times. Shaded cursor shows 'INITIAL SETUP'.
3. Press **SELECT**. Display shows:

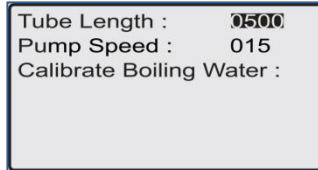

4. Press **SELECT**. '0500 mm' flashes.
5. Press **▲** or **▼** buttons to enter the correct tube length.
6. Press **SELECT**.
7. Press **BACK** twice to return to normal display.

### Boiling water flow rate

The boiling water flow rate can be adjusted to suit the installation or user preference. Extended tube lengths will require the pump speed to be increased.

8. To adjust, use the selection procedure as described above in Steps 1, 2 and 3.
9. Press **SELECT**. Shaded cursor shows 'Pump Speed 015'.
10. Press **SELECT**. '015' flashes.
11. Press **▲** or **▼** buttons to increase or decrease. Range is between 10 and 20.
12. Press **SELECT**.
13. Press **BACK** twice to return to normal display.

### Calibrating boiling water temperature (Manually)

The boiling water temperature has been factory calibrated. Because water boils at a slightly lower temperature at elevated altitudes, the factory-set temperature may be too high for units installed at certain inland locations. If the local altitude is greater than 500 metres above sea level, a calibration cycle should be performed.

The procedure is as follows;

1. Use the selection procedure as described above, in Steps 1, 2 and 3.
2. Press **SELECT** twice to select 'Calibrate Boiling Water'.
3. Press **SELECT** twice to begin cycle.
4. The unit will fill and heat (if not yet up to operating temperature before cycle begins).

**CAUTION:** Steam will discharge from the vent outlet located between the hot and cold water outlets.

Once correct boiling temperature is established, the **Quadra** recalibrates its internal settings and the display panel returns to normal.

## Installation and Commissioning Checklist

- Dispenser mounted securely.
- Dispenser swivels 45° in each direction - M4 chrome retaining screw fitted.
- Tubing is cut to correct lengths and not kinked or sagging. Red, grey and 10mm black tubes have a continual fall.
- Tubing not twisted or kinked.
- Tubing secured correctly - nuts and spring clips.
- Water main flushed before connection to unit.
- Unit connected to COLD water supply.
- Correct air clearances around unit.
- Power circuit fitted with an RCD - earth leakage protection device.
- Sawdust cleaned out of cupboard area.
- Door vents fitted correctly (air-cooled models only).
- Initial program settings correctly set for dispenser tube length.
- Time (check if daylight savings), day and date set correctly. - Refer to [Quadra User Guide](#).
- Unit heating and cooling (after initial fill). Red and blue dispenser icons flashing (or on continually when reached temperature).
- Boiling and chilled water flow correct.

If any problems or difficulties arise contact **Billi Pty Ltd**: Phone 1800 812 321 (Free call).

**Billi**<sup>TM</sup>  
IW