

Billi Sahara... easy to install

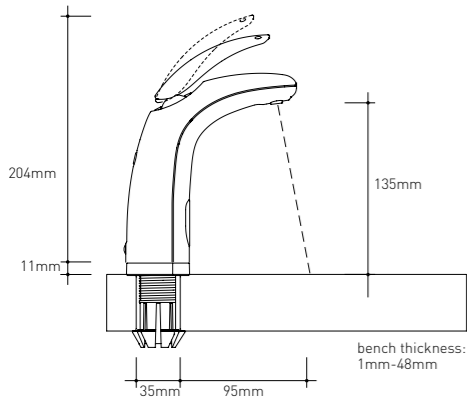

Billi Dual-Temp Dispenser dimensions

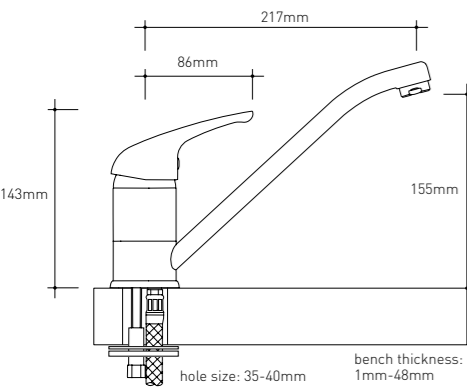

Billi Sink Mixer Tap dimensions

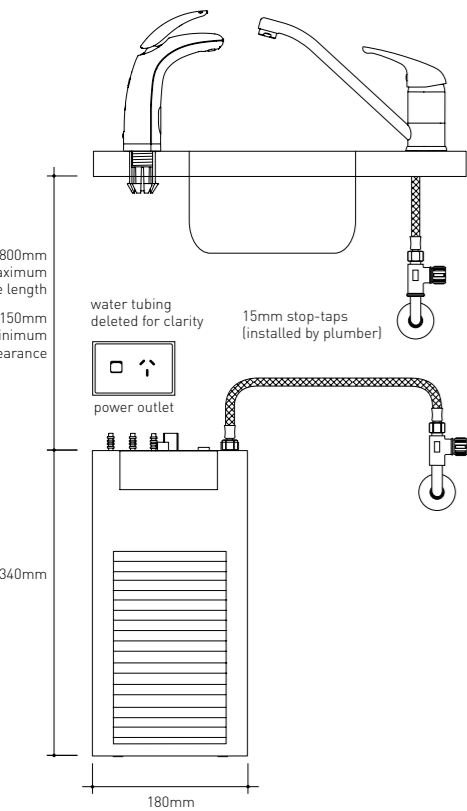

Minimum cupboard dimensions:
490mm height x 180mm width x 460mm depth
* Extra stop-tap and mixer-tap for Sahara Plus only.

Preferred installation layout

Easy installation

The Billi Sahara Dual-Temp Dispenser features a unique dispenser top-mounting system, making it a plumber's dream to install. No more tortuous reaching up behind sink bowls to secure clamps or tubes. The 'snap-fit' base is secured into the mounting hole, pipework is fed through from the top and the dispenser securely clips into place.

Water supply

A single 15mm [1/2"] stop-tap with a male thread should be installed in an easily accessible position. Water supply must be microbiologically safe to drink, with a minimum dynamic water pressure of 250kPa.

Power supply

The Billi Sahara 310, 320 & 360 and Sahara Plus 320 and 360 models require a standard 10Amp power outlet in the cupboard area where the unit is to be installed. The Billi Sahara and Sahara Plus 3120 models require a 15 Amp power outlet. All Sahara models are supplied with a 1 metre flex cord and plug.

Replacement filters

Periodic replacement of filter cartridges is necessary to maintain water quality. Genuine replacement Billi filter cartridges are available from authorised Billi agents. Cartridges are also available to suit the particular needs of different water supply areas. All Billi filters are NSF42 certified and optional sub micron filters are NSF53 certified to safely remove health threatening giardia and cryptosporidium.

Commitment to quality

Reliability has been engineered into the Billi Sahara as an imperative in the design process. Proven, high quality materials have been carefully selected for maximum dependability and longevity. The Sahara is manufactured to exacting production standards, in line with Billi's long-term commitment to quality.

24 Month Warranty

At Billi, we stand behind all of our products and offer a generous 5 year pro rata warranty on Billi Sahara's stainless steel boiling water tank. All other components are covered by a 24 month warranty. Filter cartridges are a consumable and are not covered by warranty, as water conditions and usage vary.

Certifications

Every Billi drinking water appliance is manufactured under a certified quality control system. The Billi Sahara has been tested and complies with all required standards including: Watermark Licence Number 21525; Tested to AS3498 and AS/NZS4020; AS/NZS ISO 9001 Certificate Number QEC 11627; C-Tick approved; Complies with AS1428 Requirements for Access for the Disabled and section J6 of the BCA. Victorian Electrical Safety Act 1998 Approval Number CS100600V. 



Billi Pty Ltd
42 Lucknow Crescent Thomastown
Victoria 3074 Australia
Telephone +61 3 9469 0400
Facsimile +61 3 9469 0499
Website www.billi.com.au

Designed and manufactured in Australia

As Billi Pty Ltd has a policy of continual improvement, all details are subject to change without notice. All goods are sold subject to our published terms and conditions. S0811
Billi is a registered Trade Mark. Sahara is a Trade Mark.

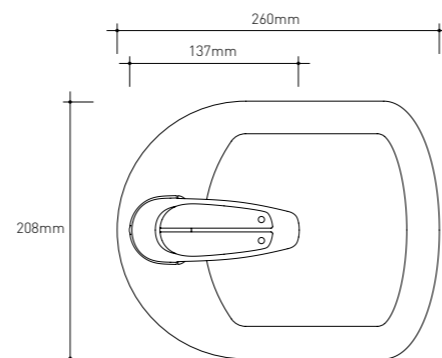

Billi Font benchtop layout



Filtered boiling and ambient drinking water system



Billi **Sahara**... an essential source of invigorating filtered boiling and ambient drinking water, instantly supplied at the touch of a lever.

The Billi Boiling System

The Billi stainless steel boiling water system has been designed to prevent temperature drop-off during periods of heavy use - an innovative breakthrough when the underbench system was originally invented by Billi.

Instant Boiling Water

To ensure your hot water is delivered as close to boiling point as possible, the **Sahara** features the automatic self-calibrating Autocal electronic temperature regulation system. Innovative delivery and recovery controls ensure temperature is maintained during periods of heavy boiling water usage.

Compact design

The Billi **Sahara** Boiling module is designed to fit comfortably within a standard shelf compartment. Its compact design allows easy installation while maximising useable cupboard space.

Great tasting drinking water

As well as supplying filtered boiling water, the dual temp dispenser also provides sparkling clean, ambient filtered water - nature's most refreshing drink. The Billi **Sahara**'s dual-stage, large capacity water filtration system effectively removes or reduces undesirable sediment, chemicals, heavy metals, chlorine, pesticides, tastes and odour.

User safety

User safety is paramount in the design of the **Sahara** dispenser tap. Its heat-insulated tap body and concealed childproof safety-switch ensure a high level of user protection. Water flow is electronically varied, slowing momentarily as water first enters the cup for smooth, splash-free delivery. A must for childcare and aged care facilities.

Time is money

An inbuilt 7-day energy-saving time switch ensures the **Sahara** is only operating when you need it, significantly reducing running costs by eliminating unnecessary out-of-hours power consumption.

No cupboard venting

Venting of the cupboard area is not required when installing a Billi **Sahara**, simplifying installation and space requirements. Air clearance around the unit is not needed and there are no grilles to keep clean or any noisy energy-consuming fans.

Billi Font - water where you want it

The stainless steel Billi Font harmonises perfectly with the **Sahara** Dual-Temp Dispenser and allows installation away from the traditional sink area. Designers have greater flexibility as the Billi Font can be easily installed where it is most needed.

Insulation for energy conservation

The **Sahara**'s energy efficiency is further enhanced with the use of high-performance insulating materials. Moulded expanded polypropylene provides a high thermal R-value rating, reducing heat losses and thereby conserving power.

Billi Sahara Plus

The Billi **Sahara Plus** not only dispenses filtered boiling and ambient drinking water - it also provides the added feature of a generous supply of instant hot water (up to 50°C). This hot water supply can be mixed with cold water and is dispensed via a separate Sink Mixer Tap, removing the need for bulky underbench hot water cylinders or energy-wasting hot water reticulation systems.

Note: Cover image includes Font kit. This is an accessory and should be ordered separately to the unit.



Innovative Billi **Sahara** design... a pleasure to use

Leakguard detection system

For peace of mind, the **Sahara** features a watertight base tray and water detection system. Should leakage ever occur, water supply to the system will be instantly shut off.

Elegant Dual-Temp Dispenser

The elegantly styled Billi **Sahara** Dual-Temp Dispenser provides filtered water, both boiling and at ambient temperature. Colour-coded levers can be pressed for single cup delivery or lifted for continuous flow. A swivel action allows the dispenser to be swung out of the way if more sink space is required. Cast from solid metal alloy, the **Sahara** Dual-Temp Dispenser is designed to withstand the rigours of high-use environments. Available in a choice of architectural finishes.

Disability conscious design

User friendly and ergonomically designed, the Billi **Sahara**'s Dual-Temp Dispenser conforms to current Australian Standards for ease of use by persons with a disability. The unique safety-switch operation, if selected, allows for full lever and hand control, thereby maintaining this compliance.

Easy-change replacement filters

Replacing the **Sahara** filter cartridge couldn't be simpler. Flashing amber dispenser icons indicate when replacement is due. The swing-change filter simply swings forward and slides off. Fitting the new filter is just as easy: slide filter in and swing back. Cartridge locks into place and a flushing cycle begins automatically.

Options and accessories

- **Finishes:** Standard finish for the **Sahara** Dual-Temp Dispenser is Bright Chrome. Optional finishes include Brushed and Black Chrome.
- **Billi Font:** Allows the **Sahara** to be located away from sink areas. Finished in polished Stainless Steel. Optional finishes include Brushed and Black Chrome.
- **Dispenser Riser:** 70mm dispenser extension - supplied standard with the Billi Font. Optional finishes include Brushed and Black Chrome.
- **1000mm Tubing Extension Kit:** Allows the dispenser to be offset from the underbench unit.

Specifications and guide to model selection

Product Code	Billi Sahara model	Initial cup delivery and suggested no. of persons	Boiling water delivery cups per hour	Heating element kW	Height mm	Width mm	Depth mm
943010	Sahara 310	10	90	1.5	340	180	360
943020	Sahara 320	20	110	1.6	340	180	460
943060	Sahara 360	60	180	2.2	340	180	460
943120	Sahara 3120	120	250	3.3	340	180	460

Product Code	Billi Sahara Plus model	50° hot water capacity litres	50° hot water delivery litres per hour	Boiling water delivery cups per hour	Heating element kW	Height mm	Width mm	Depth mm
943025	Sahara Plus 320	7	40	100	1.6	340	180	460
943065	Sahara Plus 360	9	60	180	2.2	340	180	460
943125	Sahara Plus 3120	15	85	250	3.3	340	180	460

*Based on the initial number of cups of boiling water immediately available, drawn at one cup every 10 seconds. Consideration may be needed for usage patterns and draw-off methods. 1 cup = 170ml.