B-3000
Instant Chilled Filtered
Water System

Installation guide



Installation requirements.

—B-3000 system components

1. Chilled water module
2. Slimline dispenser tap
3. Filter cartridge (installed)
4. Installation hardware
5. Drain connections
6. Billi B-3000 user guide
7. Warranty certificate

—Water supply

A single cold water supply is required.
Supply pressure: 200 – 1000 Kpa
Supply temperature: 5°C – 30°C
Do not install with water that is microbiologically unsafe or with water of unknown quality without adequate disinfection before the system. Systems certified for cyst reduction may be used on disinfected water that may contain filterable cysts.

—Power requirements

A single 10 amp standard power outlet is required. Chiller module is supplied with 1 metre of flex cord and plug.

—Drainage

A drainage point, such as a dishwasher nipple or a tundish, is required. An air gap is provided within the tap assembly.

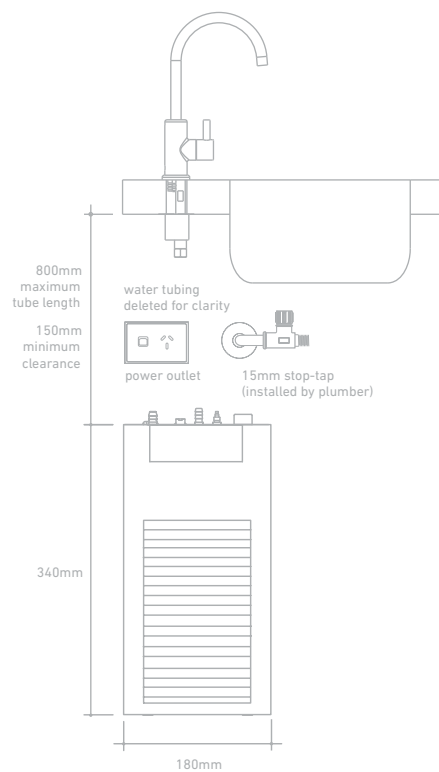
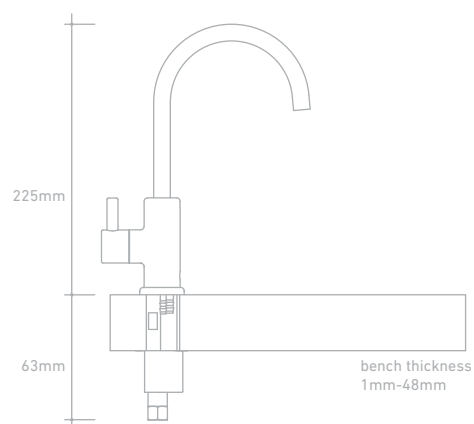

Diagram 1



billi mini chilled rounded dispenser dimension:

Diagram 2

Installing procedure.

—IMPORTANT

The Billi system is recommended to be installed on a safe tray in accordance with AS 3500.4 Clause 4.4.

—Determine component location

A stop tap (not supplied) is to be installed in an easily accessible position for later service. Determine the location of each of the components, taking into account the tube lengths and space available. Refer to Diagrams 1 and 2.

—Flush lines

It is important to flush lines before fitting. Install outlet fitting to combined valve. Refer to Diagram 4 on the following page.

—Install dispenser tap assembly

—IMPORTANT

Dispenser must not be installed below the spill level of the receiving fixture.

A 22mm hole is required either in the benchtop or flat surface of sink adjacent to bowl of sink. Mount the dispenser tap. Refer to Diagram 3.

—Install chiller module

Connect all plastic tubing as shown. Refer to Diagram 4.

All connections are made using push-fit connectors. Trim tubes to correct lengths. Tubes should be cleanly cut square using a sharp knife or plastic tube cutter.

Ensure that tube ends are round and not flattened or kinked, then push into connectors firmly until properly seated (to release, press the outer ring in while pulling gently on the tube).

—Install drain connection

The Billi dispenser tap incorporates an air break above the spill level of the sink and therefore a tundish is not required. Connect a 3/8" drain tube to dishwasher nipple, or alternative drainage point, using fittings supplied.

—IMPORTANT

Ensure drain tube has a continual fall.

—Turn on water supply

Lift dispenser tap lever and then turn on water supply. After water flows from outlet, release lever and ensure that there are no leaks. Lift lever again and run for at least 5 minutes.

—Turn on electricity supply

—Set chilled water temperature

Set the desired water temperature using blue temperature control knob. Refer to B-3000 User Guide.

—Re-check connections for leaks

—Explain operation to user

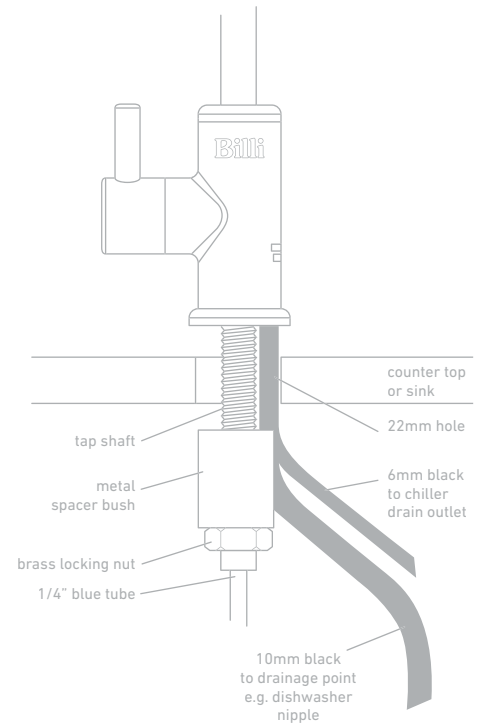

Diagram 3

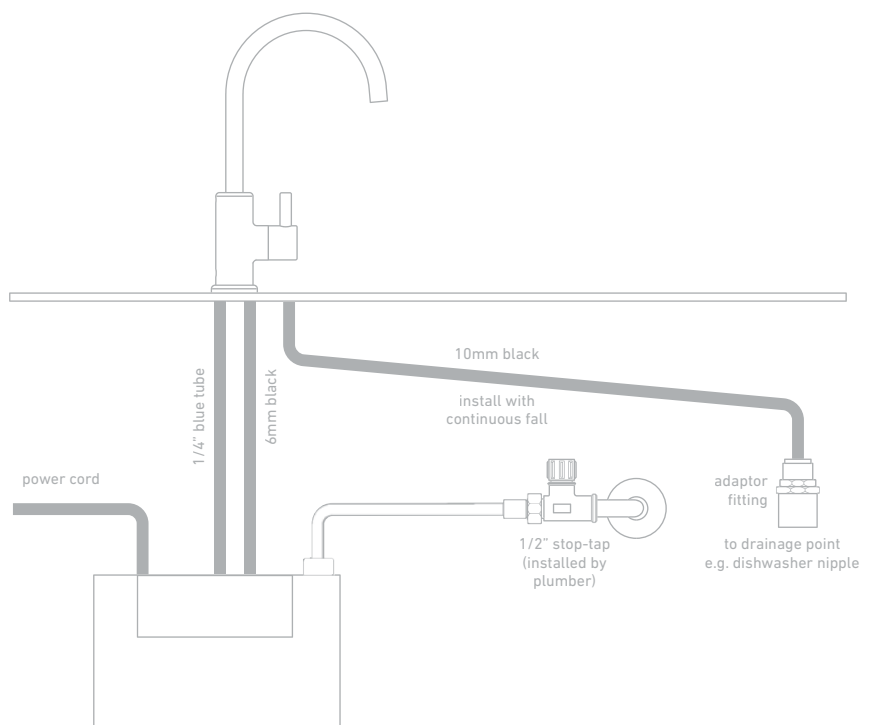

Diagram 4

WARNINGS.

For continued safety of this appliance it must be installed, operated and maintained in accordance with the manufacturer's instructions.

- Your appliance should be installed by a suitably qualified tradesperson.
- For correct operation of this appliance it is essential to observe the instructions as outlined in this booklet.
- Filter replacement must be performed at intervals of not more than 6 months.
- Use this appliance only as directed in these instructions and only for its designed purpose.
- This appliance is not intended for use by persons (including children) with reduced physical, sensory or mental capabilities, or lack of experience and knowledge, unless they have been given supervision or instruction concerning use of the appliance by a person responsible for their safety.
- Children should be supervised to ensure that they do not play with the appliance.
- If the supply cord is damaged, it must be replaced by the manufacturer, its service agent or similarly qualified persons in order to avoid a hazard.
- New hose-sets supplied with the appliance are to be used and old hose-sets should not be re-used.

Billi
HOME

Billi Pty Ltd
42 Lucknow Crescent, Thomastown
Victoria 3074 Australia

Telephone +61 3 9469 0400
Facsimile +61 3 9469 0499

www.billihome.com.au

Designed and manufactured in Australia.

As Billi Pty Ltd has a policy of continual improvement, all details are subject to change without notice. All goods are sold subject to our published terms and conditions. Billi is a registered trademark. 0610