

Billi Eco



Instant Boiling and Chilled
Filtered Water System



Billi **Eco**.

Next generation energy-efficient design.
Great tasting boiling and chilled water,
instantly.



Billi Eco – Convenience, functionality and style

Imagine the convenience of an instant supply of clean, filtered water – boiling or chilled – at any time of the day or night. Along with a compact and elegant design, the **Billi Eco** offers energy-efficiency and cost savings. It also complies with green building design guidelines, providing the ultimate in environmentally sensitive appliances.

Instant boiling water

With the innovative Billi electronic temperature regulation system and precise temperature monitoring functions, hot water is always within 1°C of boiling point. So there will never be a temperature drop-off, even during high-use periods.

Water perfectly chilled

Users can vary the chilled water temperature to suit personal taste and the seasons. A simple adjustable control allows the temperature to be raised to 15°C or lowered to 6°C for perfectly chilled, refreshing drinks, with your required temperature being quickly reached and maintained.



High-tech filtration system

Billi's premium filters ensure that impurities such as sediment, chemicals, heavy metals, chlorine and pesticides are safely removed while fluorides are retained, leaving users with refreshingly clean drinking water, every time. All Billi filters are NSF42 certified and optional sub micron filters are NSF53 certified to safely remove health threatening giardia and cryptosporidium.

Safety first

Safety is paramount in the design of the **Billi Eco** dispenser. With its heat insulated body and concealed childproof safety-switch, there is a high level of user protection. Billi's **Splash Free™** boiling water delivery means that flow is electronically varied, slowing momentarily to eliminate splashing as the water first enters the cup.

Energy efficient

With the highly energy-efficient **Billi Eco**, users can lessen their environmental impact and save on power bills. **New Eco Intelligence™** software allows the **Billi Eco** to operate only when required. Not only that, the system monitors daily usage patterns and even recognises evening and weekend changes in routine to effectively minimise energy consumption. Or an energy-saving standby mode can be selected that will activate after a preset period of non-use.



High performance insulation

Superior insulation is critical to the sustainability performance of any integrated boiling system. Designed with environmental factors in mind, the **Billi Eco** utilises Billi's unique **Thermostore™** technology and sophisticated insulating materials to operate at a level of efficiency which exceeds 50 times that of traditional hot water tanks.

Ventilation

Because it generates far less heat than other filter systems, the **Billi Eco** does not require cupboard ventilation or an external cooling fan. Instead, its design incorporates a unique air cooling system that further enhances energy efficiency and removes the need for cabinet alterations.



Innovative, space-saving Billi **Eco**... a pleasure to use

Billi Eco – Save on space

With a focus on space-saving, the compact **Billi Eco** has been designed to simply integrate into any storage module design. Less than half the size of other units on the market, it fits easily within a standard cupboard compartment.

Flexible font positioning

Combining design flexibility with supreme functionality, the Billi Font can be easily installed wherever it is needed, whether in the sink area or elsewhere – maximising the way space is utilised. And with its classic simplicity, the Billi Font will coordinate with other design features and appliances.

Functional style

The elegantly styled and ergonomically designed Billi dispenser is a pleasure to use. Colour-coded levers are position-sensitive, allowing control of boiling water flow rate. Users simply press a lever for a single cup or lift for continuous flow. A swivel action swings the dispenser out of the way if more sink space is required. Cast from solid metal alloy, the dispenser is designed to withstand the rigours of high-use environments.

Easy-change replacement filter

Replacing the **Billi Eco** filter cartridge is simple. Flashing amber dispenser icons indicate when replacement is due. The swing-change filter simply swings forward and slides off. Fitting the new filter is just as easy – simply slide the filter in and swing it back. The cartridge locks into place.

Disability conscious design

Designed for all users, the **Billi Eco**'s lever operations meet current Australian Standards relating to access for people with a disability.

Leakguard detection system

With the **Billi Eco**, there is no need to worry about water leakages. To ensure peace of mind, a watertight base tray and water detection system have been incorporated into the system's design. If a water leakage should ever occur, the water supply is instantly shut off.

Commitment to quality

A strong commitment to quality is as important to Billi as style, function and innovation. Recognising the importance of reliability to customers, all Billi water systems are manufactured to strict quality standards and built to last. And every system is designed to provide the highest possible standards of efficiency and energy savings.



Space-saving Billi **Eco**... easy to install

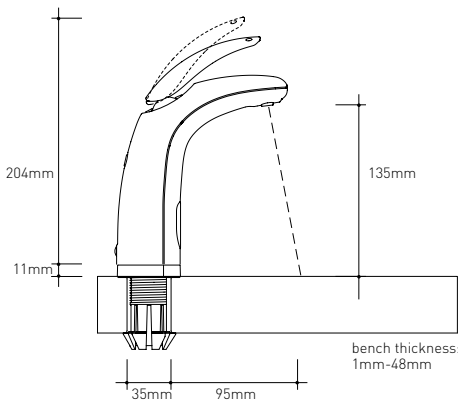

Billi Dual-Temp Dispenser dimensions

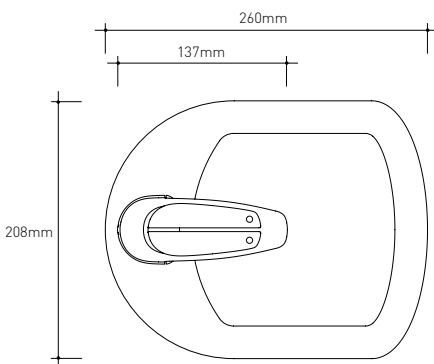

Billi Font benchtop layout (Dual-Temp only)

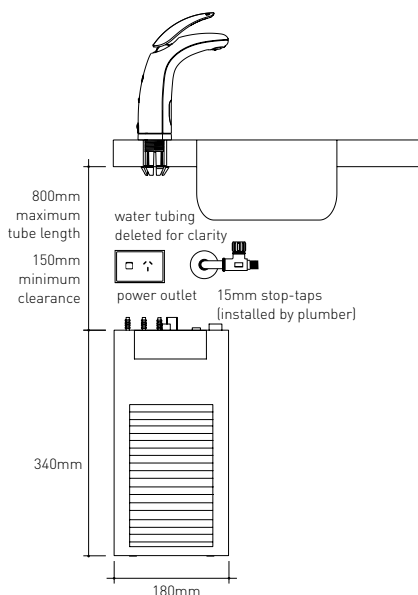

Preferred installation layout

Minimum cupboard dimensions:
490mm height x 180mm width x 500mm depth

Options and accessories

- **Dispenser finishes:** Standard finish for the **Billi Eco** dispenser is bright chrome. Optional finishes include black and brushed chrome.
- **Billi Font:** Allows the **Billi Eco** to be located away from sink areas and finished in polished stainless steel. Optional finishes include black and brushed chrome.
- **Dispenser riser:** 70mm dispenser extension – supplied standard with the Billi Font. Optional finishes include black and brushed chrome.
- **Extension kit:** Available for installations where the dispenser needs to be offset from the underbench unit.

Easy installation

The **Billi Eco** dispenser features a unique top-mounting system, making it simple to install. There is no need to reach up behind sink bowls to secure clamps or tubes – the 'snap-fit' base is secured into the mounting hole, pipework is fed through from the top and the dispenser securely clips into place.

Water supply

A single 15mm (1/2") stop-tap with a male thread should be installed in an easily accessible position. The water supply must be microbiologically safe to drink, with a minimum dynamic water pressure of 250kPa.

Power supply

The **Billi Eco** requires a standard 10 amp power outlet. It is supplied with a 1 metre flex cord and plug.

Replacement filters

Periodic replacement of filter cartridges is necessary to maintain water quality. Genuine replacement Billi filter cartridges are available online at www.billi.com.au and from local approved suppliers. Cartridges are also available to suit the needs of different water supply areas.

24 Month Warranty

All components of the **Billi Eco** are covered by a 24 month warranty. Filter cartridges are a consumable and are not covered by warranty, as water conditions and usage vary.

Certifications

Every Billi drinking water appliance is manufactured under a certified quality control system. The **Billi Eco** has been tested and complies with all required standards, including: Watermark Licence Number 21525; tested to AS3498 and AS/NZS4020; AS/NZS ISO 9002 Certificate Number QEC 11627; C-Tick approved; complies with AS1428 requirements for access for the disabled and section J6 of the BCA. Electrical compliance number CS100600V.

Specifications and guide to model selection

Billi Eco Product Code	Model	Initial cup delivery and suggested no. of persons	Boiling water delivery cups per hour	Chilled water delivery cups per hour	Heating Element kw	Total Current Draw amps	Height mm	Width mm	Depth mm
901000	Eco	10	90	60	1.5	10	340	180	500



Billi Pty Ltd

42 Lucknow Crescent Thomastown
Victoria 3074 Australia
Telephone +61 3 9469 0400
Facsimile +61 3 9469 0499
Website www.billi.com.au

Designed and manufactured in Australia

As Billi Pty Ltd has a policy of continual improvement, all details are subject to change without notice. All goods are sold subject to our published terms and conditions.

Billi is a registered Trade Mark. E0811