

COMMERCIAL DATA SHEET

Alpine 125 XT

Billi™

Billi Alpine 125 with XT Touch Dispenser

Enjoy refreshing chilled or a continuous supply of ambient temperature filtered water. Billi's Alpine 125 offers a premium filtered drinking water experience to account for all preferences. The XT touch dispenser is an innovative, contemporary design, which has a touch sensitive panel offering a sophisticated and clean style.



XT Touch Dispenser

Alpine Under-Bench Unit



Features



PRODUCT SPECIFICATIONS

Water type	Product code	Model name	Dispenser	Suggested no. of people	Chilled water delivery (cups per hour)	Still water delivery (cups per hour)	Power supply (amps)
 STILL CHILLED	932125T	Alpine 125	XT Touch	Up to 40	120	unlimited	10

Accessories

992800 - 70mm Riser & Font

992820 - 70mm Riser

992803 - 120mm Riser & Font

992830 - 120mm Riser



990720 - Tubing Extension Kit for X series dual temp dispensers 2mtrs

Finishes

Standard Finishes



Special Order Finish

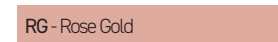

Add the Finish code to the Product Code to finalise your specification, eg. 932125TCH

TECHNICAL DRAWING & INSTALLATION REQUIREMENTS

PRODUCT DIMENSIONS

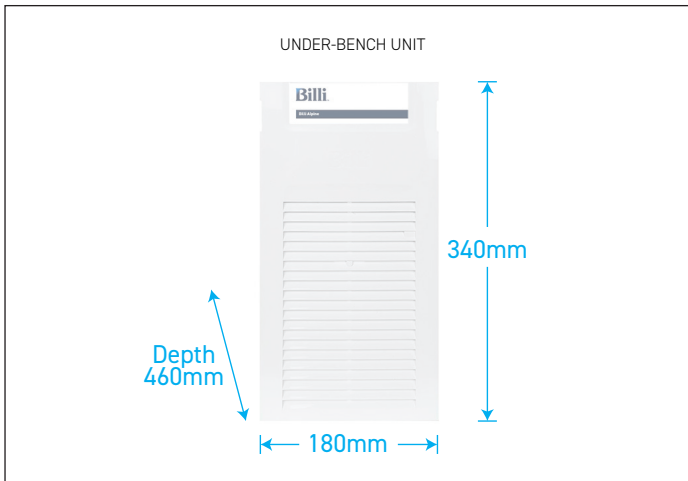
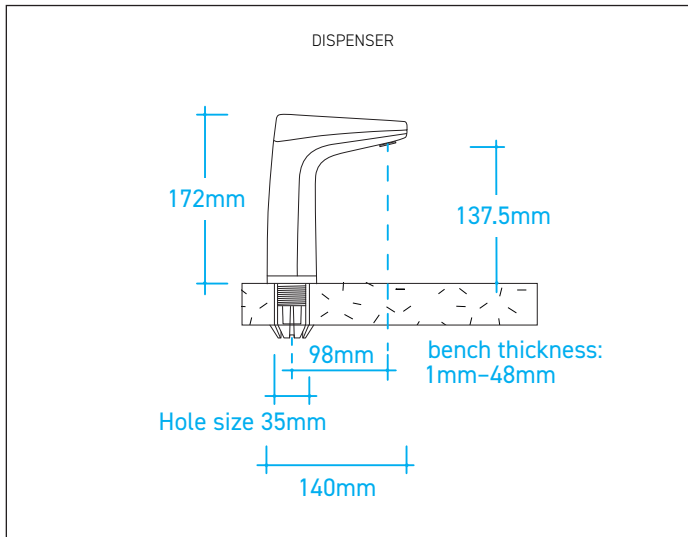

PREFERRED INSTALLATION LAYOUT

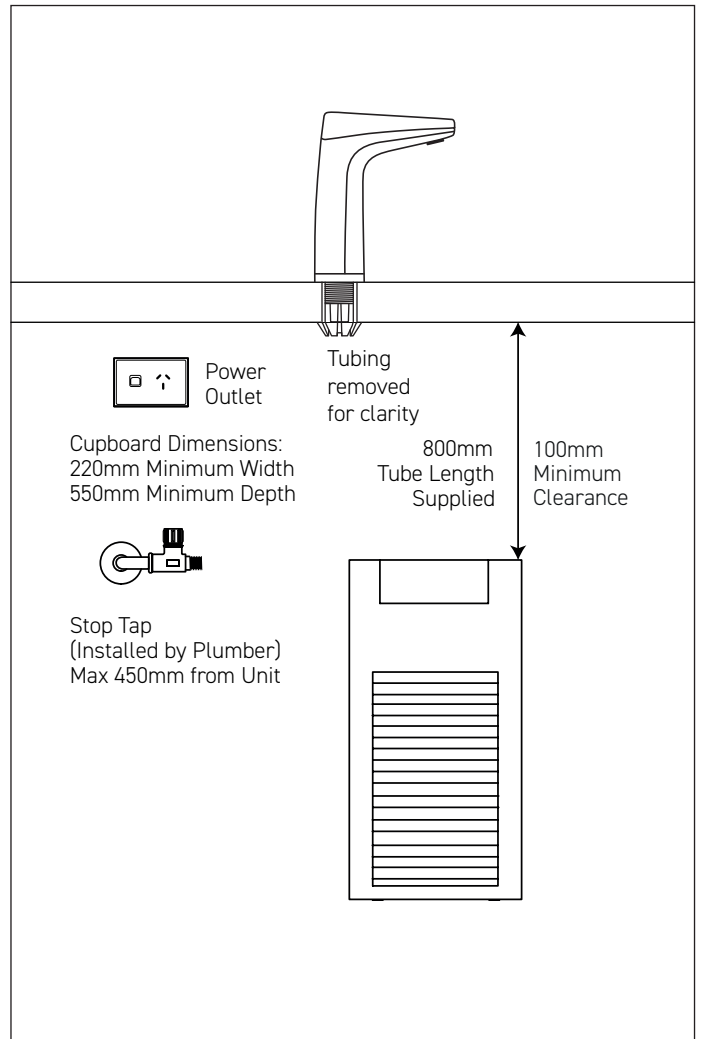

WATER SUPPLY

A single 1/2" BSP (15mm) stop-tap with a male thread should be installed in an easily accessible position. Water supply must be microbiologically safe to drink, with a minimum dynamic water pressure of 250kPa and a maximum of 1000kPa.

POWER SUPPLY

A standard 10 amp power outlet is required, no further than 1000mm from the underbench unit. The system is supplied with a 1 metre flex cord and plug.

FILTRATION

Billi's range of premium filters utilise BWT's unique Fibron X technology. Billi's filter range provides superior taste, water quality, consistent filter life and peace of mind when it comes to hygiene.

Filter supplied: 994051 (5 micron). Replacement filters available: 994052 (0.2 micron), 994054 (HSD), 994055 (XPHSD), 994056 (Sediment only) and 994060 (0.2 micron sediment only).

CERTIFICATIONS

Every Billi drinking water appliance is manufactured under a certified quality control system. All Billi commercial range models have been tested and comply with all required standards including: WaterMark: WM-021882; HACCP: PE-872-WAT-1-02; ISO 9001:2015, QEC 11627; Tested to ATS5200.105 and AS/NZ 4020; Section J6.6 of the BCA; WELL Cornerstone Member.

WARRANTY

The Billi Alpine Range is covered by a comprehensive 2 year warranty on all parts and labour.

Billi™

Billi Australia Pty Ltd
42 Lucknow Crescent,
Thomastown, Victoria
3074 Australia

P 1800 812 321
F +61 3 9469 0499
W www.billi.com.au

visit us at



Designed and manufactured in Australia to the highest quality standards