

# COMMERCIAL DATA SHEET

## Quadra Compact Safety



### Billi Quadra Compact with Safety Dispenser

The Quadra Compact Boiling and Chilled drinking water system is a high capacity, intermediate population commercial drinking water solution that maintains the core Billi design principles and requires no joinery ventilation.

The drawback for the entire Quadra range is the use of innovative energy reclaim technology which enables space savings, energy efficiency and completely eliminates exhaust heat transfer.

All Quadra boiling and chilled products are Global GreenTag certified to a Gold standard.

The globally distributed Safety Dispenser was designed in consultation with industry experts and is regarded as the best fit-for-purpose solution currently available in Australia. Ideal for high security or critical care environments, including correctional facilities and mental health care units.



BOILING



CHILLED



Safety Dispenser



Quadra Under-Bench Unit



### Features

- SPACE SAVING DESIGN
- SAFE TO OPERATE
- ENERGY EFFICIENT
- HEAT EXCHANGE TECHNOLOGY
- WATER COOLED TECHNOLOGY
- NO CUPBOARD VENTILATION REQUIRED
- AUSTRALIAN DESIGNED & MADE
- GREENTAG CERTIFIED
- EASY INSTALLATION

## PRODUCT SPECIFICATIONS

Water type	Product code	Model name	Dispenser	Suggested no. of people	Boiling water delivery (cups per hour)*	Chilled water delivery (cups per hour)	Power supply (amps)
 BOILING CHILLED	904010V	Quadra Compact	Safety	Up to 20	100	150	10

\* Based on the initial number of cups of boiling water immediately available, drawn one cup every 10 seconds. For all underbench filtered water systems, consideration may be needed for usage patterns and draw-off methods. 1 cup = 170ml

### Accessories

990718CH - QL Font for Safety dispenser

990720 - Tubing Extension Kit for X series dual temp dispensers 2mtrs



### Finishes

Standard Finish

CH - Chrome

Add the Finish code to the Product Code to finalise your specification, eg. 904010VCH

# TECHNICAL DRAWING & INSTALLATION REQUIREMENTS

## PRODUCT DIMENSIONS

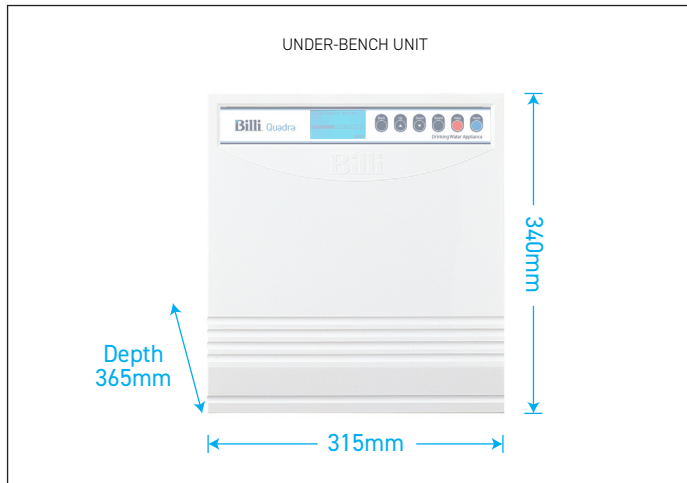
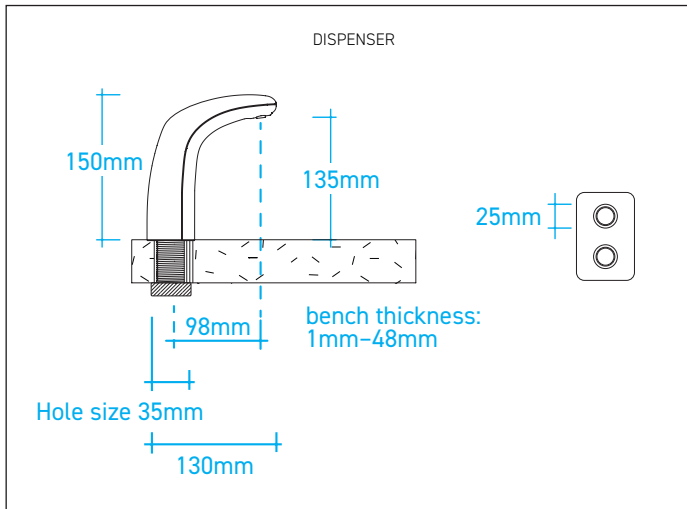

## PREFERRED INSTALLATION LAYOUT

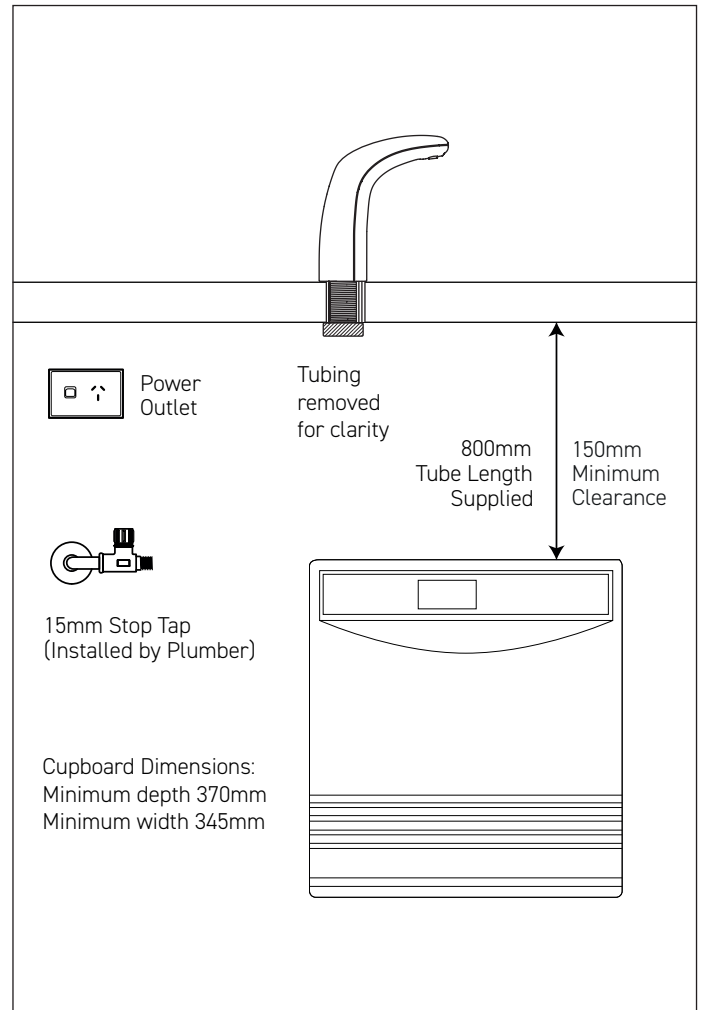

### WATER SUPPLY

A single 1/2" BSP (15mm) stop-tap with a male thread should be installed in an easily accessible position. Water supply must be microbiologically safe to drink, with a minimum dynamic water pressure of 250kPa and a maximum of 1000kPa.

### POWER SUPPLY

A standard 10 amp power outlet is required, no further than 1000mm from the underbench unit. The system is supplied with a 1 metre flex cord and plug.

### FILTRATION

Billi's range of premium filters utilise BWT's unique Fibron X technology. Billi's filter range provides superior taste, water quality, consistent filter life and peace of mind when it comes to hygiene.

Filter supplied: 994051 (5 micron). Replacement filters available: 994052 (0.2 micron), 994054 (HSD), 994055 (XPHSD), 994056 (Sediment only) and 994060 (0.2 micron sediment only).

### CERTIFICATIONS

Every Billi drinking water appliance is manufactured under a certified quality control system. All Billi commercial range models have been tested and comply with all required standards including: Watermark: WM-021525; Certified to AS/NZ3498 and AS/NZ 4020; ISO9001:2015, QEC 11627; Section J6.6 of the BCA; Global GreenTag LCARate Gold; HACCP: PE-872-WAT-1-02; WELL Cornerstone Member.

### WARRANTY

The Billi Quadra Range is covered by a comprehensive 2 year warranty on all parts and labour.

# Billi™

Billi Australia Pty Ltd  
42 Lucknow Crescent,  
Thomastown, Victoria  
3074 Australia

P 1800 812 321  
F +61 3 9469 0499  
W www.billi.com.au

visit us at



Designed and manufactured in Australia to the highest quality standards