

Quadra Sparkling Plus Specification Sheet



Featuring a separate mixer tap complete with its own hot water supply, operating as your hot water service and still providing boiling, chilled and sparkling drinking water.



XL Levered with Paddle Mixer in Chrome

The Quadra Sparkling plus system is a filtered boiling, chilled & sparkling water system which provides boiling, chilled and sparkling water instantly. The plus range includes a separate sink mixer that dispenses hot and cold filtered water.

Adjustable sparkling water

Adjust the level of sparkling to suit your taste with adjustable controls up to 5 bar of CO₂ pressure.

Adjustable chilled temperature

The new Billi sparkling models have an improved chilling capacity & recovery time. A simple adjustable control knob allows the chilled water temperature to be raised or lowered for chilled and refreshing drinks.



Gooseneck Mixer in Chrome

* To order a square mixer change Product code on page 2 from LP to LG

New Ice Bank technology for chilled and sparkling water

Our Ice bank technology has a chilled reservoir where both sparkling and chilled water supply passes through. In doing so, the dispensed water temperature is consistently chilled, also providing a higher level of carbonation.

Safety first

Billi's SplashFree™ boiling water delivery electronically varies the water flow, slowing momentarily to eliminate splashing as the water first enters the cup. All Billi dispensers are supplied standard with a safety switch.

Eliminates the need for an additional hot water service

The Billi Quadra Sparkling Plus incorporates its own hot water service all in the two small underbench units.

Boiling water reserve

The Quadra Sparkling Plus unit has a boiling water reserve to ensure you will always have boiling water after the hot water supply through the mixer tap is fully drawn.

Improved performance, increased chilled & sparkling cup capacity from 60 cups to 100 cups & 120 cups to 200 cups.

Packaging to include CO₂ canister.



Square Mixer in Chrome

* To order a square mixer change Product code on page 2 from LP to LS

Quadra Sparkling Plus Specification Sheet

Specifications and guide to standard model selection

Product Number	Description	Suggested no. of people	50°C Hot water delivery litres / hour	Chilled & sparkling cups / hour	Boiling cups / hour	Power required (amps)		Unit Height (mm)	Unit Width (mm)	Unit Depth (mm)
906065LPCH	Quadra Sparkling Plus 9 XL & Paddle Chrome	Up to 60	60	200	180	2 x 10	C&S Boiling	410 340	255 180	420 460
906105LPCH	Quadra Sparkling Plus 15 XL & Paddle Chrome	Up to 100	85	200	250	1 x 10 1 x 15	C&S Boiling	410 340	255 180	420 460

Please note: The BCS Sparkling consists of two modules, the Chilled and Sparkling (C&S) module, and the Boiling module. All Models come in a range of dispenser options and finishes. The codes shown on this table are for XL Dispenser in Chrome only. You can view the options and Product Codes here: http://billi.com.au/wp-content/uploads/2015/08/Billi-Product-Selection-Guide_0217.pdf

Electrical installation requirements

The Quadra Sparkling plus consists of two modules and both require their own power outlet. Quadra Sparkling Plus 9 requires 2 x 10 amp outlets and Quadra Sparkling Plus 15 requires 1 x 10 amp outlet & 1 x 15 amp outlet. It is supplied with a 1 metre flex cord and plug.

Water supply

A single 15mm (1/2") BSP stop-tap with a male thread should be installed in an easily accessible position. Water supply must be microbiologically safe to drink, with a minimum dynamic water pressure of 250kPa to a maximum of 1000kPa.

CO₂ Gas Cylinder

The CO₂ gas cylinder supplied must be secured in a suitable location. Each cylinder contains 1100g of CO₂ and should be installed in a well ventilated area. Each cylinder will provide between 200-350L of sparkling water depending on the unit settings. The MSDS is available on www.billi.com.au for a complete list of specifications and warnings. Replacement CO₂ gas cylinders are available from Billi.

Warranty

All components of the Billi units are covered by a 24 month warranty. Filter cartridges are a consumable and are not covered by warranty, as water conditions and usage vary.

Technical Advice

Contact Billi Pty Ltd on 1800 812 321

Refer to installation guide for full details including ventilation requirements.

Filtration

Billi have partnered with globally recognised brand Pentair Everpure to create the most technologically advanced filtration for instant boiling and chilled filtered water systems. It removes sediment and chemicals, allows the flow of minerals through without scale build up and suppresses harmful bacteria in the water. Due to the unique Fibredyne™ technology, our filters have a longer life, higher flow rate and lower pressure drop, leaving you with healthy fresh water. All Billi cartridges are certified by NSF International.

Filter changes are made simple by our swing-change system and replacement cartridges are available online at www.billi.com.au. Optional sub micron filters are available.

Certifications

Every Billi drinking water appliance is manufactured under a certified quality control system. Billi Sparkling models have been tested and comply with all required standards including: Watermark; Licence 022690; Tested to; ATS5200.105 and AS/NZS4020; AS1428 Accessibility Design Requirements; ISO9001 Certificate Number QEC 11627.



Preferred installation layout

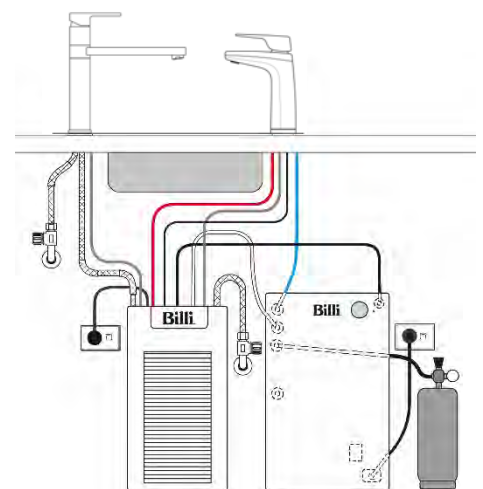

XL Levered tap dimensions

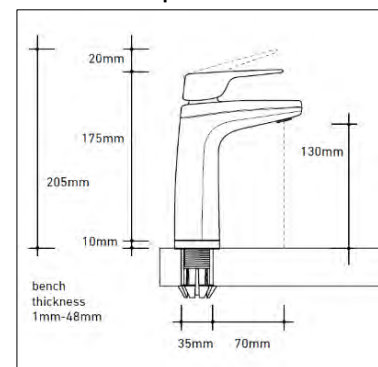

1 cup = 170ml. Based on the initial number of cups of boiling water immediately available, drawn one cup every 10 seconds. Consideration may be needed for usage patterns and draw-off methods.