

# HOME DATA SHEET

## B5000 Sparkling XL

# Billi™

### Billi B5000 Sparkling with XL Levered Dispenser

The B5000 Sparkling system is the ultimate multi-use home water appliance. Delivering instant boiling & chilled water with the added luxury of sparkling filtered water at your fingertips.

All output preferences are dispensed from a single stylish above bench tap, with concealed safety lock feature and available in a range of designer finishes to suit any modern kitchen.

Supplied standard with 994052 sub-micron filtration from BWT to deliver the freshest tasting water and ensure the health of your family & guests.



BOILING



CHILLED



SPARKLING

XL Levered Dispenser



B5000 Sparkling Under-Bench Unit



### Features



SAFE TO OPERATE



ENERGY EFFICIENT



SPLASHFREE DELIVERY



ADJUSTABLE CHILLED TEMPERATURE



ADJUSTABLE SPARKLING LEVEL



ICE BANK TECHNOLOGY



RANGE OF FINISHES





HACCP CERTIFIED



ITALO-AUSTRALIAN PARTNERSHIP

# Australian design & made Boiling unit \* Italian design & made Sparkling unit

## PRODUCT SPECIFICATIONS

Water type	Product code	Model name	Dispenser	Power supply (amps)	Suggested usage
   BOILING CHILLED SPARKLING	915100L	B5000 Sparkling	XL Levered	2x10	<ul style="list-style-type: none"> <li>• Drinking water filtration</li> <li>• Cooking &amp; Food preparation</li> <li>• Instant Hot or Chilled beverages</li> <li>• Sterilisation of baby bottles</li> <li>• Cocktails &amp; Mocktails</li> </ul>

\* Based on the initial number of cups of boiling water immediately available, drawn one cup every 10 seconds. For all underbench filtered water systems, consideration may be needed for usage patterns and draw-off methods. 1 cup = 170ml

### Accessories

992800 - 70mm Riser & Font



992820 - 70mm Riser



992803 - 120mm Riser & Font



992830 - 120mm Riser



990726 - Tubing Extension Kit for Sparkling unit - 2mtrs

### Finishes

#### Standard Finishes

CH - Chrome	BR - Brushed
MB - Matte Black	MW - Matte White

#### Special Order Finishes

RG - Rose Gold	BRG - Brushed Rose Gold	GM - Gun Metal Grey
PL - Platinum	UB - Urban Brass	

Add the Finish code to the Product Code to finalise your specification, eg. 915100LMB

# TECHNICAL DRAWING & INSTALLATION REQUIREMENTS

## PRODUCT DIMENSIONS

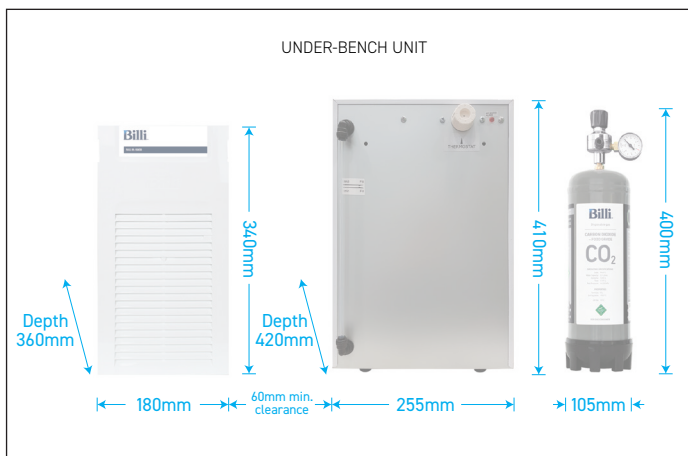
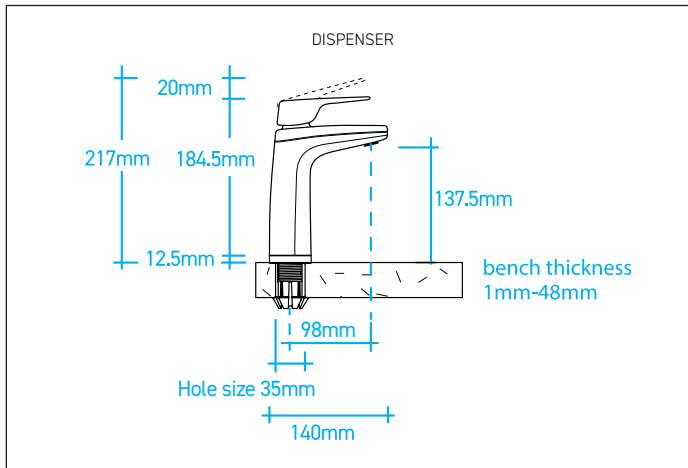

## PREFERRED INSTALLATION LAYOUT

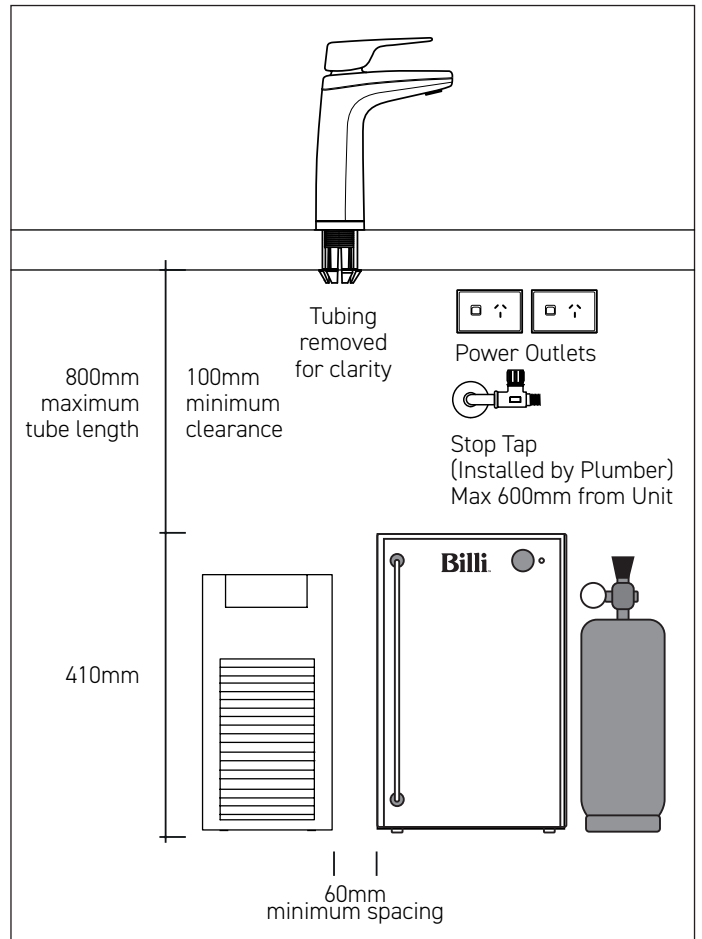

### WATER SUPPLY

A single 1/2" BSP (15mm) stop-tap with a male thread should be installed in an easily accessible position. Water supply must be microbiologically safe to drink, with a minimum dynamic water pressure of 250kPa and a maximum of 1000kPa.

### POWER SUPPLY

Two (2 of) standard 10 amp power outlets are required, no further than 1000mm from the underbench unit. The system is supplied with a 1 metre flex cord and plug.

### FILTRATION

Billi's range of premium filters utilise BWT's unique Fibron X technology. Billi's filter range provides superior taste, water quality, consistent filter life and peace of mind when it comes to hygiene.

Filter supplied: 994052 (0.2 micron). Replacement filters available: 994051 (5 micron option), 994054 (HSD option), 994055 (XPHSD Fibron XP), 994056 (Sediment only) and 994060 (Micron HF Sediment Only).

### CERTIFICATIONS

Every Billi drinking water appliance is manufactured under a certified quality control system. All Billi commercial range models have been tested and comply with all required standards including: Watermark: WM-022690; Tested to AT5200.105 and AS/NZ 4020; ISO 9001:2015, GEC 11627; AS1428; WELL Cornerstone Member.

### CO<sub>2</sub> Cylinder

The CO<sub>2</sub> gas cylinder supplied must be secured in a suitable location. Each cylinder contains 1100g of CO<sub>2</sub> and should be installed in a well ventilated area. Each cylinder will provide between 200-350L of sparkling water depending on the unit settings. The MSDS is available on [www.billi.com.au](http://www.billi.com.au) for a complete list of specifications and warnings. Replacement gas cylinders are available from Billi. CO<sub>2</sub> Cylinder - single 996911 or double 996912.

### WARRANTY

The Billi B5000 Sparkling Range is covered by a comprehensive 2 year warranty on all parts and labour.

# Billi™

Billi Australia Pty Ltd  
42 Lucknow Crescent,  
Thomastown, Victoria  
3074 Australia

P 1800 812 321  
F +61 3 9469 0499  
W [www.billi.com.au](http://www.billi.com.au)

visit us at



Designed and manufactured in Australia to the highest quality standards