

Billi OmniOne Pro 20 with XL Levered Dispenser

The OmniOne is the latest iteration of multifunction filtered drinking water appliances from Billi. The intersection of genuine innovation and sustainable design, OmniOne integrates Billi's renowned water-cooling and energy reclaim technologies into a single space-saving under bench control module.

The OmniOne range is the ultimate inclusion to the modern workplace or facility.

The XL levered dispenser is streamlined and elegant, offering boiling and chilled output delivered safely and at your own pace simply by operating the position-sensitive levers.



BOILING



CHILLED



SPARKLING



Up to 20

Features



AUSTRALIAN
DESIGNED
& MADE



WATER
COOLED
TECHNOLOGY



HEAT
EXCHANGE
TECHNOLOGY



VENT-FREE
INSTALLATION



ENERGY
EFFICIENT



FRESHER
SPARKLING
TASTE

XL Levered
Dispenser



OmniOne Pro 20
Under-Bench Units



Finishes

Standard Finishes

Special Order Finishes



CH -
Chrome



BR -
Brushed



MB -
Matte Black



MW -
Matte White



UB -
Urban Brass



GM -
Gun Metal Grey

Add the relevant Finish Code to the Product code to complete your specification eg 926020LCH-LF

Accessories

990726 - Tubing extension kit for Sparkling - 2 metres

Product Specifications

Water Type	BCS
Dispenser	L - XL Levered Dispenser
Mixer Tapware	N/A
Product Code	926020L
Warranty	3 years manufacturers warranty
Under-Bench Dimensions	395mm(W) x 355mm (H) x 495mm (D)
Boiling Output	Up to 120 cups per hour
Chilled* Output	Up to 220 cups per hour
Sparkling* Output	Up to 220 cups per hour
50°C Hot Water Output	N/A
Min / Max Dispenser Temp	6°C / 99°C
Power Plug	10amp
Power Rating	1500W, 220-240V, 50-60Hz
Water Pressure	Min. 250kPa
Ecolabel	N/A
EPD	N/A
Greenstar Contribution	N/A
Watermark License	WM-021525
Lead Free	✓
Section J7.7 (NCC)	✓
WELS	N/A
WELL	Cornerstone Membership
Management Systems	Every Billi drinking water appliance is manufactured under the strictest standards and is certified in accordance with: ISO9001 for QMS (FS 790754), ISO14001 for EMS (EMS 801468) and ISO45001 for OSHS (OHS 801469).
Food Handling	NA
Filtration	994051 - 5.0 Micron supplied standard

*Combined usage for Chilled and Sparkling.

Scan the QR code access
our Revit families on

bimstore

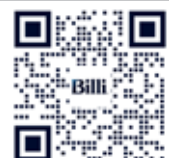

Technical Drawings

DISPENSER

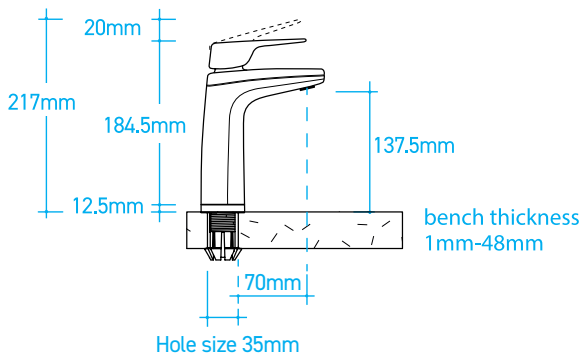

UNDER-BENCH UNITS

Billi OmniOne Unit

CO₂ Cylinder



Installation Requirements

Cupboard Dimensions:
520mm Minimum Width
550mm Minimum Depth

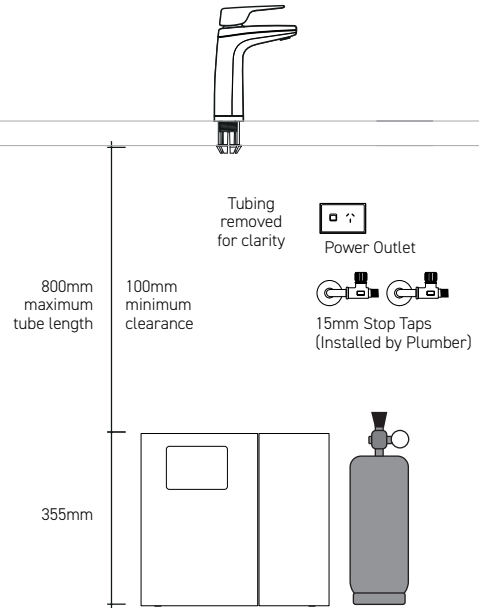

Installation Notes

Electrical

A standard 10 amp power outlet is required, located no further than 1000mm from the underbench unit. The system is supplied with a 1 metre flex cord and plug.

Water

A single 1/2" BSP (15mm) stop-tap with a male thread should be installed in an easily accessible position. Water supply must be microbiologically safe to drink, with a minimum dynamic water pressure of 250kPa and a maximum of 1000kPa.

Pressure Valve

Integrated 500kPa pressure limiting and dual check valve is pre-installed to the unit inlet.

CO₂ MSDS

The CO₂ gas cylinder supplied must be secured in a suitable location. Each cylinder contains 1100g of CO₂ and should be installed in a well ventilated area. Each cylinder will provide between 200-350L of sparkling water depending on the unit settings. The MSDS is available on www.billi.com.au for a complete list of specifications and warnings. Replacement gas cylinders are available from Billi. CO₂ Cylinder - single 996911 or double 996912.

Stone Benches

Billi has a no-cut policy regarding all stone benches in compliance with regulations. The safety of our team and customers remains Billi's top priority.

Ventilation

No joinery ventilation or accessories are required for this Billi product (water cooled technology and/or no waste heat).

Filtration - Most Recommended Replacement Filters

Billi range of premium filters utilize BWT's unique FibronX® technology, providing superior taste, water quality, filter life longevity and peace of mind when it comes to hygiene.



994051 - (5.0 micron)

Supplied standard.
Commercial & high volume sites.



994052 - (0.2 micron)

Fine filtration.
Residential or Critical Care sites.

*Drawings are for guidance during Specification, refer to Installation requirements for final install. All efforts are made to ensure Compliance & Certifications claims are current, however this is subject to change without notice. Billi assumes no liability or responsibility for out of date information.



Please scan the QR code for all support information.

Billi Australia Pty Ltd

P 1800 812 321
W www.billi.com.au

Billi New Zealand Ltd

P 0800 636 0 636
W www.billi.co.nz

Billi