

# SPECIFICATION DATA SHEET - RM 33 BUBBLER

# Billi™

Delivering up to 30 litres of chilled water per hour, the RM Bubbler satisfies the hydration needs of demanding environments such as: schools, fitness clubs, factories and more. Made from tough, durable materials, this bubbler is recommended for outdoor areas and locations that are usually exposed to harsh weather and rough-use conditions.



### Features and Benefits

- IP33 Rating
- Capacity suitable for high volume areas
- 100% rust proof and UV stabilised cabinet to prevent material degradation
- Impact resistant construction
- Includes standard drinking spout and convenient bottle filler
- Strong built and dependable, ideal for outside environments
- Expansion valve to protect from mains water pressure surges
- Granite style finish
- Recommended for use with Pre-Filter kit 994114 (Sold Separately)

IP33

## RM 33 BUBBLER PRODUCT SPECIFICATIONS

Product code	Model name	Capacity	Chilled water delivery glasses per hour	Weight	Power supply (amps)	HxWxD mm
 988016	RM 33 Bubbler	30L/hour	175*	28kg	10	1180x410x410

CHILLED

### Recommended Filter Kit

Product	Model	Capacity	Micron Rating	Description
994114	15" Pre-filter kit	57,000 litres chlorine reduction	5 Micron	High flow pre-filter kit including mounting bracket & housing, required connections and PLV.

Water temperature at 5°C.

\*Based on the initial number of glasses of chilled water immediately available, drawn one cup every 10 seconds.

# TECHNICAL DRAWING & INSTALLATION REQUIREMENTS

## Installation Connections

### POWER SUPPLY

A 1.5 metre cordset with standard 3 pin plug is provided. Power consumption Ambient temp 25° (kw.h/24h) 0.044.

### WATER SUPPLY

The inlet is an industry standard 1/2" female BSP threaded connection situated on the rear of the cooler.  
(See installation instructions for exact rough in details).

### DRAIN OUTLET

The drain outlet and integrated 'P' trap provide an industry standard 40mm connection situated on the rear of the cooler.  
(See installation instructions for exact rough in details).

## Product Dimensions

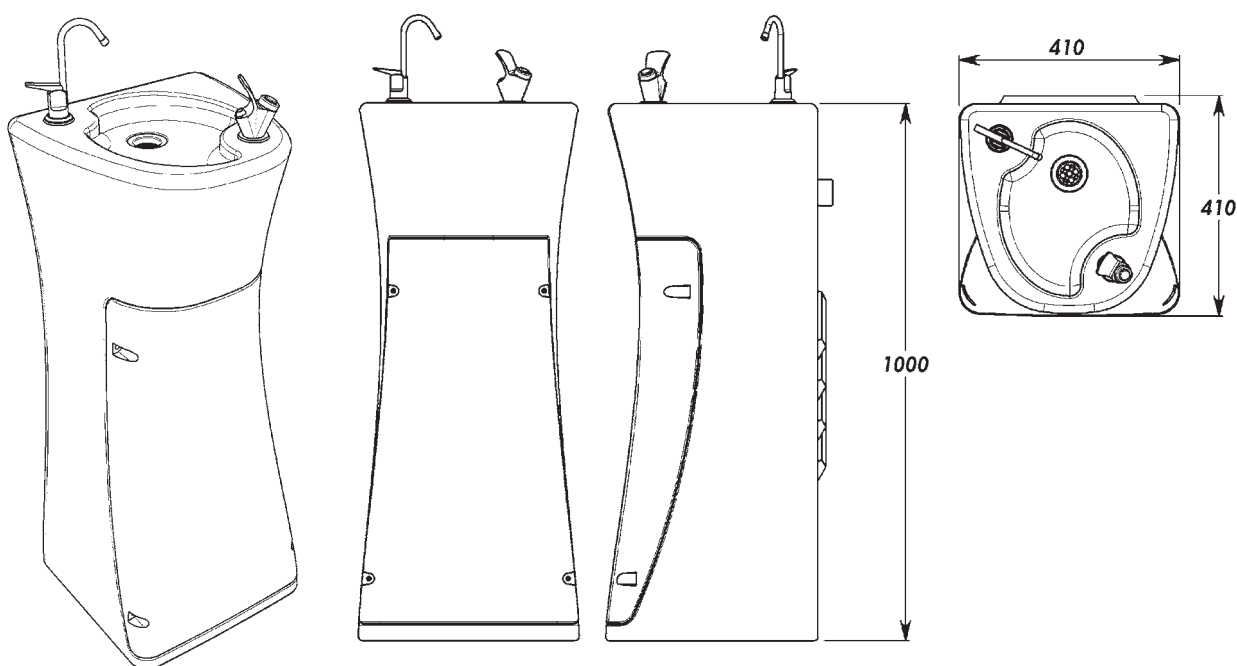

### INLET:

860mm above base  
100mm Left of centre line  
(from back)

### OUTLET:

860mm above base  
30mm Left of centre line  
(from back)

# Billi™



**Billi Australia Pty Ltd**  
42 Lucknow Crescent,  
Thomastown, Victoria  
3074 Australia

**P** 1800 812 321  
**F** +61 3 9469 0499  
**W** www.billi.com.au

visit us at

